

JK808 Control Submersible Pump



	Page
- SPECIFICATIONS	
Features & Applications	100
Typical Exploded View	101
Pump & Motor Specifications	102
Selection Chart / Type key	103
- PERFORMANCE CURVES	
Performance Curve Specifications	200
Performance Curve - ZXP371 70/05, 70/07	201
Performance Curve - 90/10	202
Performance Curve - 120/07, 120/12, CDX 120/20	203
Performance Curve - 200/12 200/20, CDX 200/25	204
- CONSTRUCTIONS	
Constructions – Sectional View	300
Constructions – Exploded View	301
Constructions – Mechanical Seal	302
Constructions – Diagram and Electrical Connections – Single Phase	303
Constructions – Diagram and Electrical Connections – Three Phase	304
- DIMENSIONS	
Dimensions	400
Packing and Weight	401
- TECHNICAL DATA	
Technical Data – Motor and Bearings	500

SUBMERSIBLE PUMP

FEATURES AND APPLICATIONS

50 Hz
V14



Stainless steel single impeller centrifugal pumps. Featuring the one piece volute manufactured using Supertec unique plasma stamping process.

Specifications

Maximum working pressure : 8 bar
Maximum liquid temperature: 60°C (for models 70/05-70/07-90/10)
90°C (for other models)

Materials

Pump casing: 304 Stainless Steel
Impeller: 304 Stainless Steel
Casing Cover: 304 Stainless Steel
Shaft : 303 Stainless Steel (part in contact with liquid)
Bracket & Motor Frame: Aluminium
Mechanical seal: Carbon/Ceramic/NBR

Motor Data

TEFC, 2 pole motor
Insulation class F
IP55 protection
50 Hz, 3 phase - 415 Volt, 1 phase - 240 Volt
In built overload protection for 1 phase

Range

0.37 to 1.5 kW - 1 phase
0.37 to 1.8 kW - 3 phase

Supply

1.8 m cable & plug with 1 phase models
Optional high temperature seal available (110°C)
(Carbon/Ceramic/Viton seal, Viton O' Rings)
Optional hard faced seal available
(SiC/SiC/Viton seal, Viton O' Rings)

SUBMERSIBLE PUMP

TYPICAL EXPLODED VIEW

50 Hz
V14

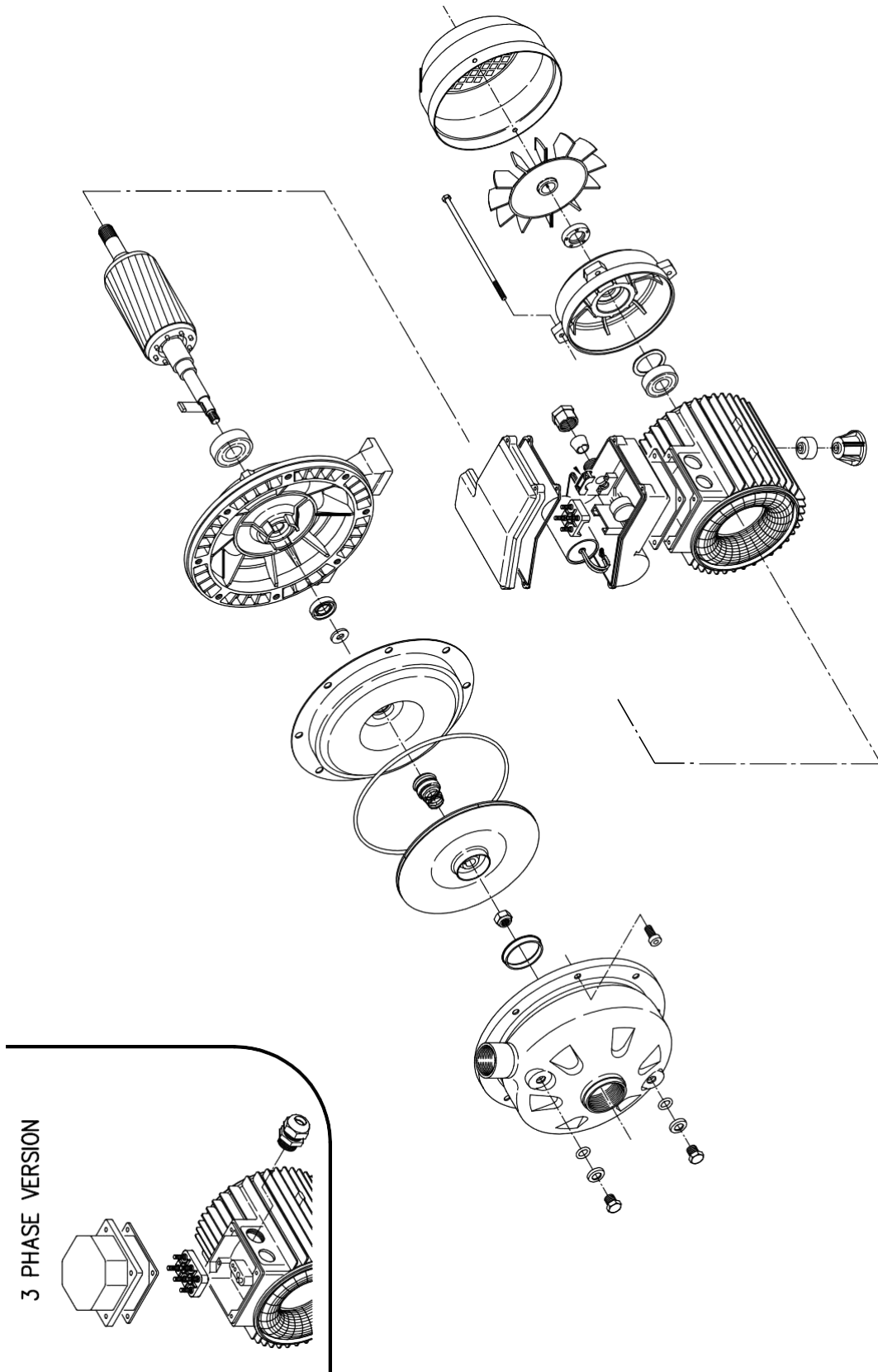

SUBMERSIBLE PUMP

PUMP AND MOTOR SPECIFICATIONS

50 Hz

V14

PUMP		
Liquid Handled	Type of liquid	Clean water
	Max temperature [°C]	60 (CDX 70/05-70/07-90/10) 90
	Min temperature [°C]	-10
Maximum working pressure [MPa]		0.8
Construction	Impeller	Closed centrifugal type
	Shaft seal type	Mechanical seal
	Bearing	Sealed ball bearing
Pipe Connection	Suction	G 1¼ (G 1½ CDX200)
	Discharge	G 1
Material	Casing	AISI 304
	Impeller	AISI 304
	Casing cover	AISI 304
	Shaft seal	Ceramic/Carbon/NBR (Standard) Ceramic/Carbon/FPM (High temp seal - optional) SiC/SiC/FPM (Hard face seal - optional)
	Shaft	AISI 303 (Wet extension)
	Bracket	Aluminium
Applicable standard of test		ISO 9906 – Annex A

MOTOR		
Type	Single Phase Electric - TEFC Three Phase	
Efficiency level (Reg. 640/2009)	-	- from 0.37 kW up to 0.55 kW IE2 from 0.75 kW up to 1.8 kW
No. of Poles	2	
Rotation speed [min ⁻¹]	≈ 2800	
Insulation Class	F	
Protection degree (CEI EN 60034-5)	IP 55	
Power rating	[kW]	0.37 ÷ 1.5
	[HP]	0.5 ÷ 2
Frequency [Hz]	50	
Voltage [V]	230 ±10%	230/400 ±10%
Capacitor	Built in	-
Over load protection	Built in	Provided by the user
Casing material	Aluminium	
Base material/motor support	Aluminium	
Dimensions of cable entry	PG11 - PG13.5 (see dimensions page 400)	

SUBMERSIBLE PUMP

50 Hz

SELECTION CHART / TYPE KEY

V14

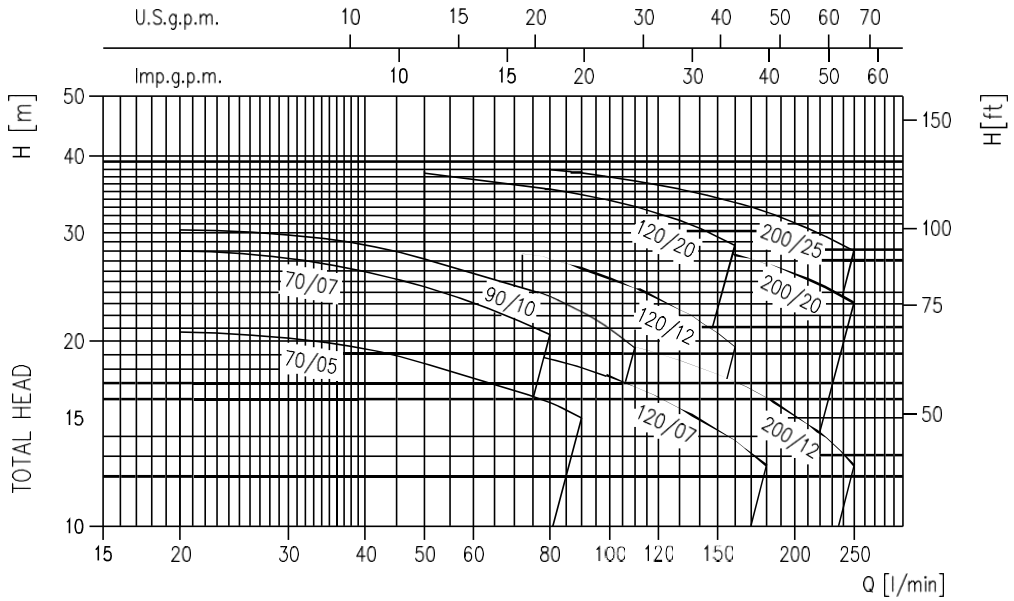

Type pumps		Power		Q=Capacity											
Single Phase	Three Phase	[kW]	[HP]	l/min 20	50	80	90	110	130	160	180	210	250		
				m ³ /h 1.2	3	4.8	5.4	6.6	7.8	9.6	10.8	12.6	15		
				H=Total manometric head in meters											
CDXM 70/05	CDX 70/05	0.37	0.5	20.7	18.4	15.9	15	-	-	-	-	-	-		
CDXM 70/07	CDX 70/07	0.55	0.8	28	24.5	20.5	-	-	-	-	-	-	-		
CDXM 90/10	CDX 90/10	0.75	1	30.3	27.2	23.6	22.3	19.5	-	-	-	-	-		
CDXM 120/07	CDX 120/07	0.55	0.8	-	20.5	18.7	18.1	16.8	15.5	13.7	12.5	-	-		
CDXM 120/12	CDX 120/12	0.9	1.2	-	29.5	27.1	26.1	24.3	22.4	19.5	-	-	-		
CDXM 120/20	CDX 120/20	1.5	2	-	37.5	35.3	34.6	33.1	31.4	28.6	-	-	-		
CDXM 200/12	CDX 200/12	0.9	1.2	-	-	20.6	20.2	19.5	18.5	17.1	16.1	14.6	12.5		
CDXM 200/20	CDX 200/20	1.5	2	-	-	31	30.6	29.7	28.9	27.5	26.6	25.1	23		
-	CDX 200/25	1.8	2.5	-	-	38	37.5	36.4	35.3	33.6	32.4	30.5	28		

TYPE KEY:

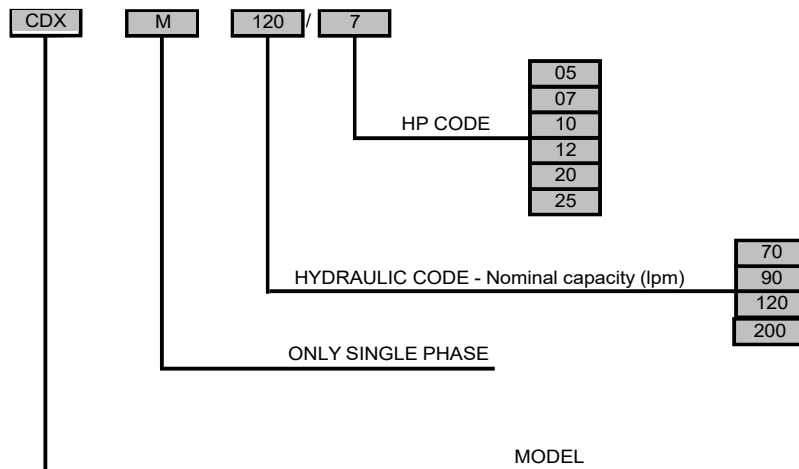

SUBMERSIBLE PUMP

PERFORMANCE CURVE SPECIFICATIONS

50 Hz

V14

PERFORMANCE CURVE SPECIFICATIONS

The specifications below qualify the curves shown on the following pages.

Tolerances according to ISO 9906 Annex A

The curves refer to effective speed of asynchronous motors at 50 Hz

Measurements were carried out with clean water at 20°C of temperature and with a kinematic viscosity of $\nu = 1 \text{ mm}^2/\text{s}$ (1 cSt)

The NPSH curve is an average curve obtained in the same conditions of performance curves.

The continuous curves indicate the recommended working range. The dotted curve is only a guide.

In order to avoid the risk of over-heating, the pumps should not be used at a flow rate below 10% of best efficiency point.

Symbols explanation:

- Q = volume flow rate
- H = total head
- P_2 = pump power input (shaft power)
- η = pump efficiency
- NPSH = net positive suction head required by the pump
- MEI = minimum efficiency index

The minimum efficiency index (MEI) is a measure of the quality of a pump size in respect to its mean efficiency. The minimum efficiency index is based on the hydraulic efficiency and on the head at the best efficiency point.

The efficiency of a pump with trimmed impeller is usually lower than that of a pump with the full impeller diameter. The trimming of the impeller will adapt the pump to a fixed duty point, leading to reduced energy consumption. The minimum efficiency index (MEI) is based on the full impeller diameter.

The operation of these water pumps with variable duty points may be more efficient and economic when controlled, for example, by the use of a variable speed drive that matches the pump duty to the system.

MEI = 0.4 for ESCC 2900 rpm

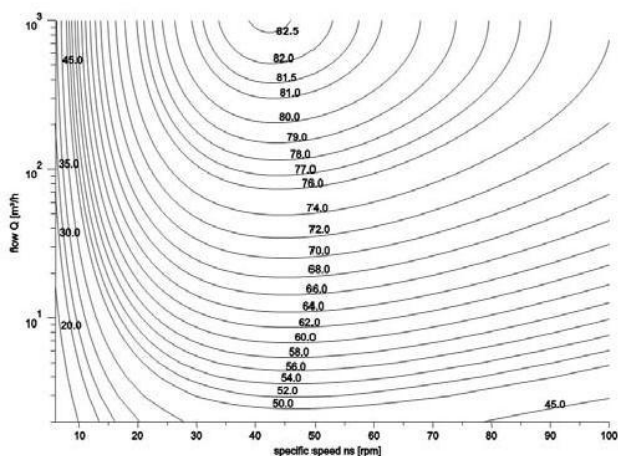

MEI = 0.7 for ESCC 2900rpm

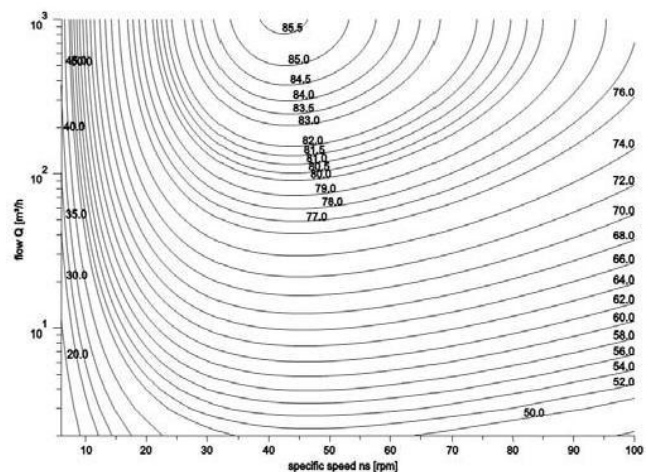

SUBMERSIBLE PUMP

PERFORMANCE CURVE

50 Hz
V14

CDX 70/05 (0.37 kW) Impeller diameter = 132
CDX 70/07 (0.55 kW) Impeller diameter = 157

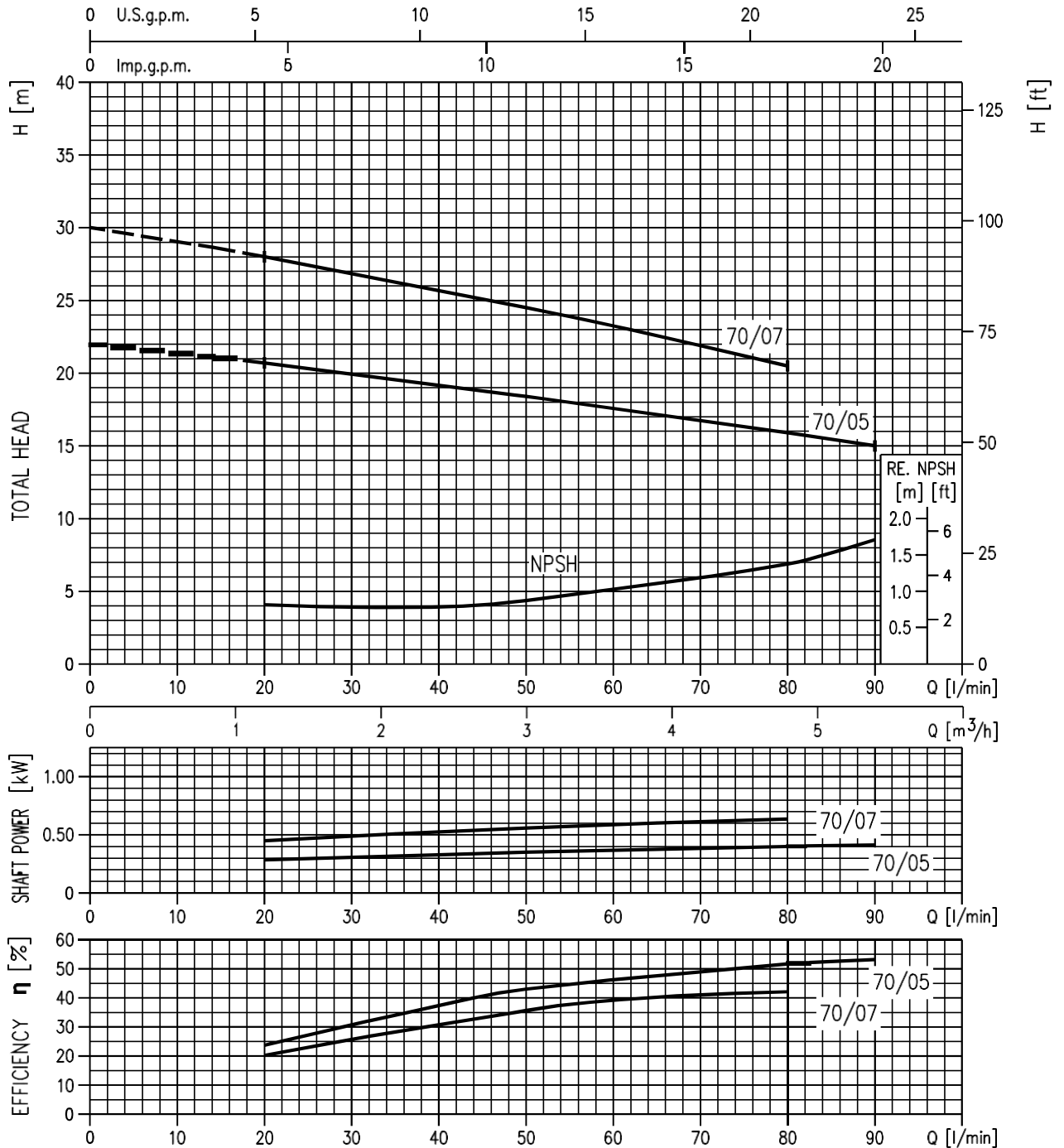

Rotation speed: $\approx 2800 \text{ min}^{-1}$
 Test fluid: clean water at 20°C
 Applicable standard of test: ISO 9906 – Annex A

SUBMERSIBLE PUMP

PERFORMANCE CURVE

50 Hz
V14

90/10 (0.75 kW) MEI > 0.70 - Impeller diameter = 157 mm

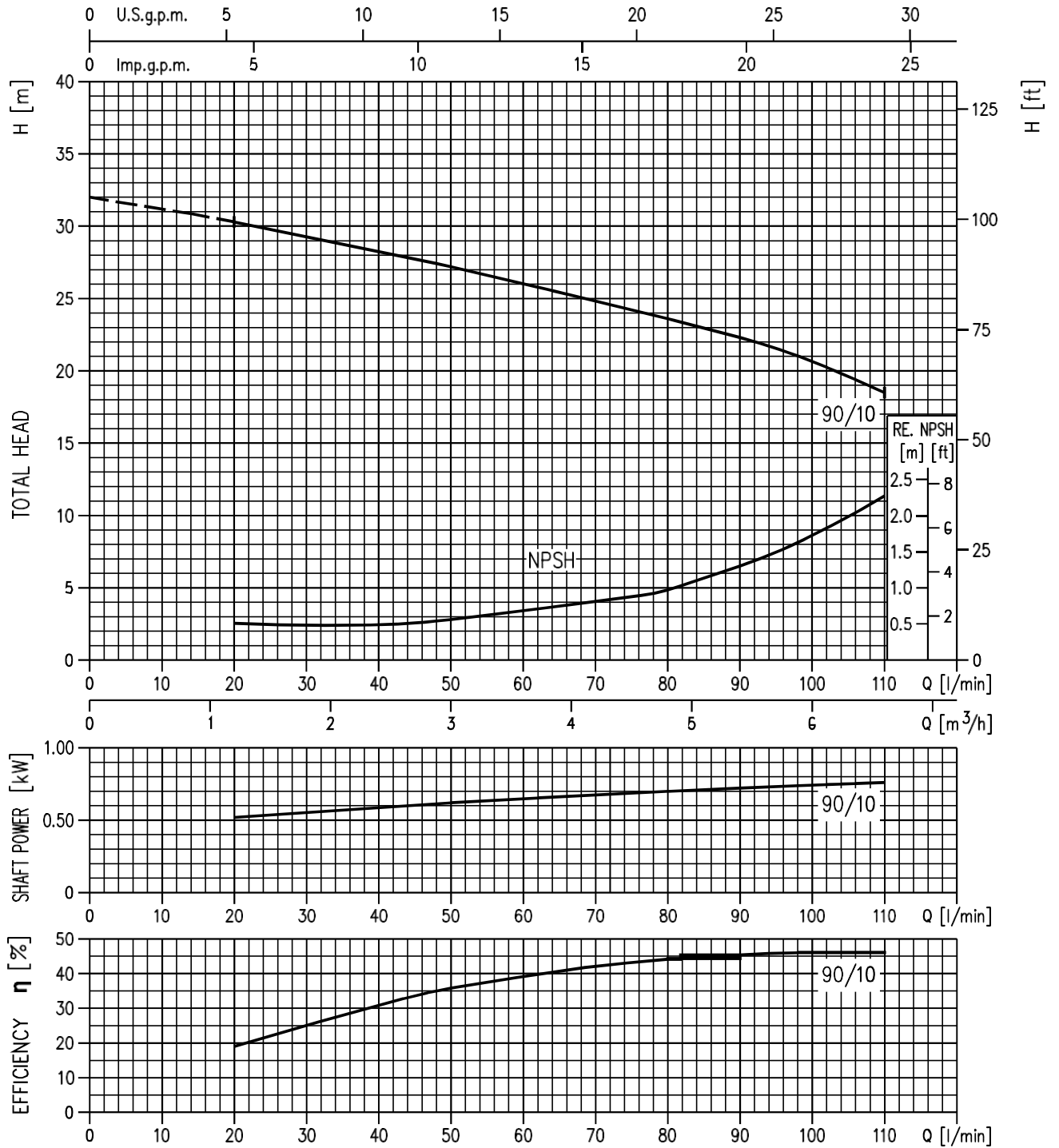

Rotation speed $\approx 2800 \text{ min}^{-1}$
Test standard: ISO 9906 – Annex A

SUBMERSIBLE PUMP

PERFORMANCE CURVE

50 Hz
V14

120/07 (0.55 kW) MEI > 0.50 - Impeller diameter = 132 mm
 120/12 (0.90 kW) MEI > 0.30 - Impeller diameter = 157 mm
 120/20 (1.50 kW) MEI > 0.70 - Impeller diameter = 176 mm

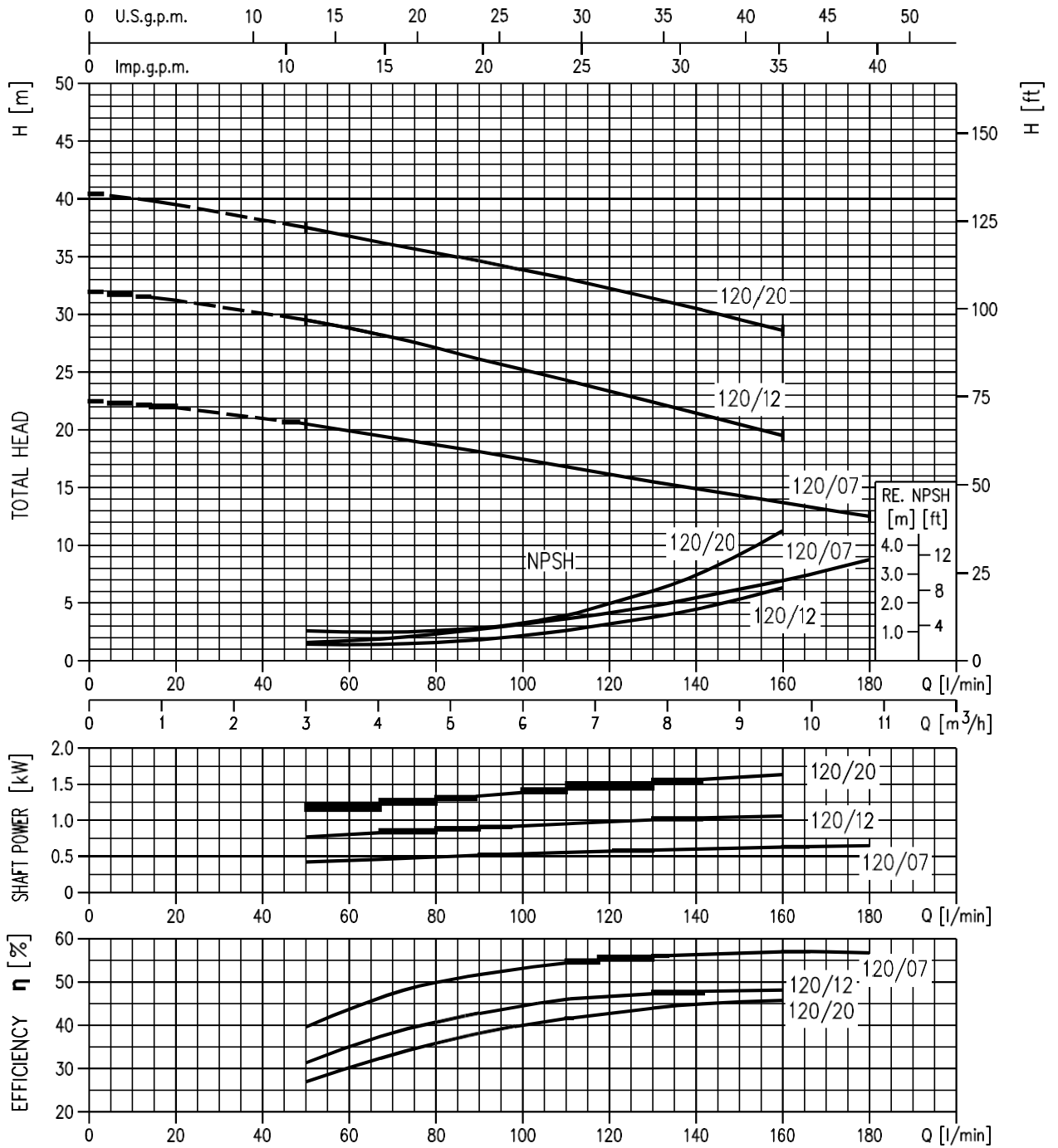

Rotation speed $\approx 2800 \text{ min}^{-1}$
 Test standard: ISO 9906 – Annex A

SUBMERSIBLE PUMP

PERFORMANCE CURVE

50 Hz
V14

200/12 (0.9 kW) MEI > 0.30 - Impeller diameter = 132 mm
200/20 (1.5 kW) MEI > 0.30 - Impeller diameter = 157 mm
200/25 (1.8 kW) MEI > 0.30 - Impeller diameter = 176 mm

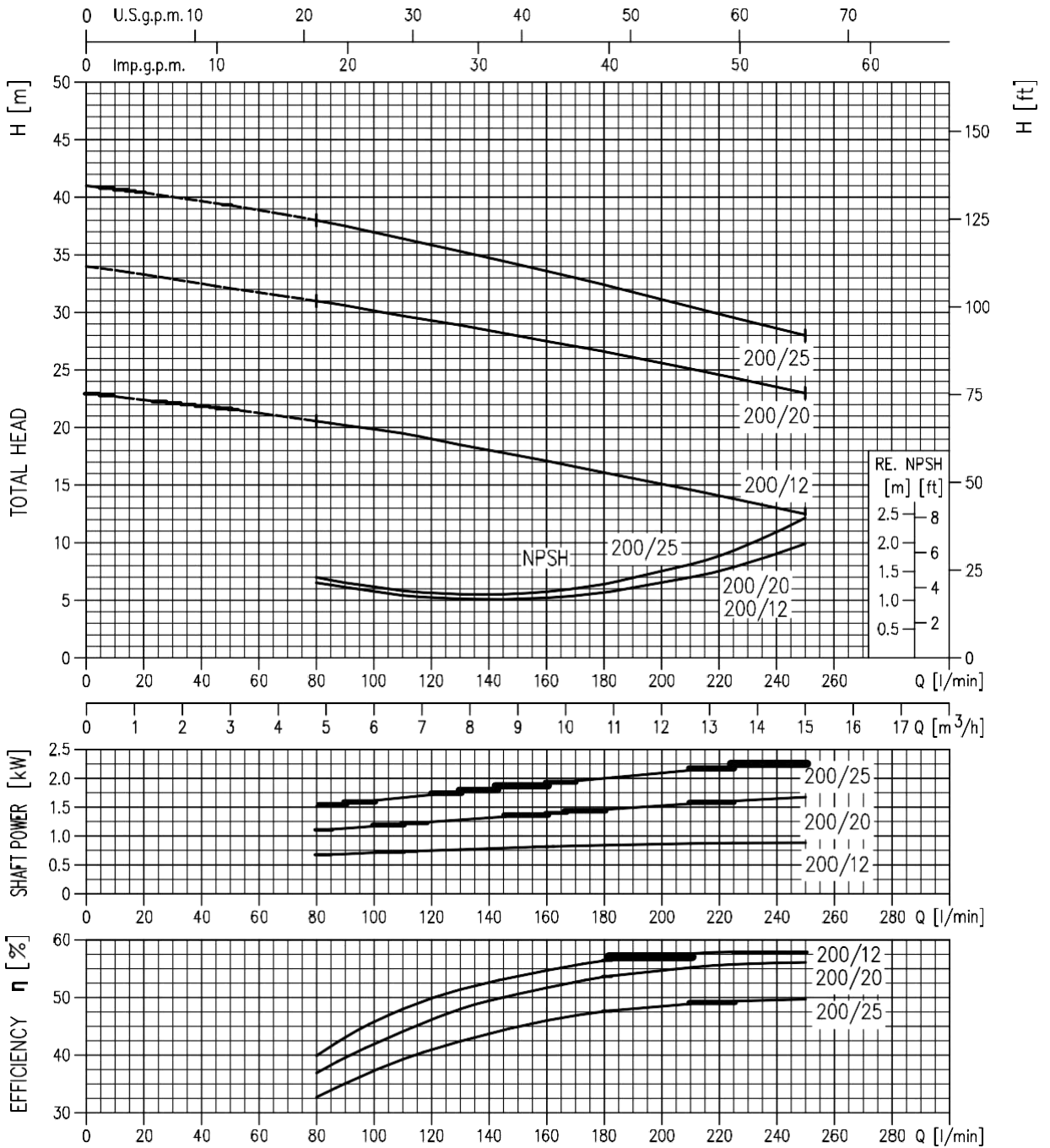

Rotation speed $\approx 2800 \text{ min}^{-1}$
 Test standard: ISO 9906 – Annex A

SUBMERSIBLE PUMP

CONSTRUCTIONS - SECTIONAL VIEW

50 Hz
V14

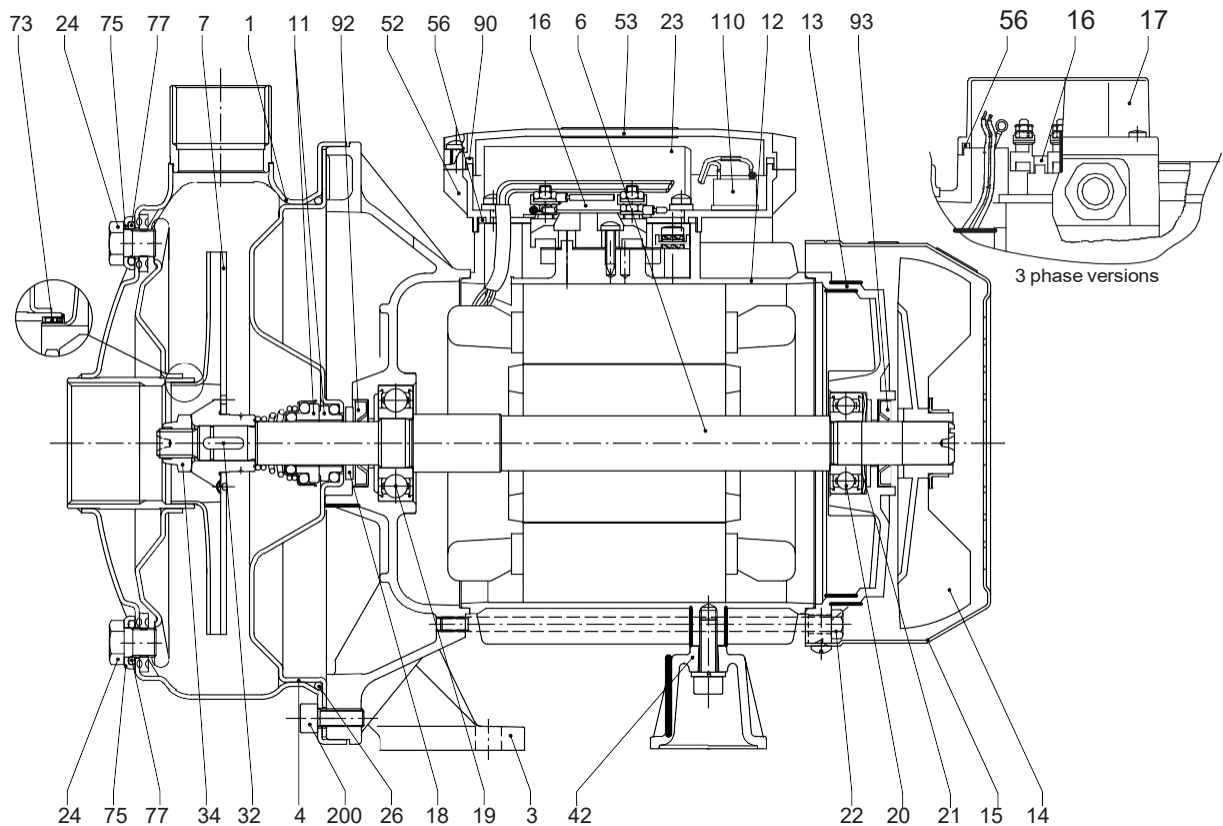

No.	PART NAME	MATERIAL	QTY	No.	PART NAME	MATERIAL	QTY	No.	PART NAME	MATERIAL	QTY
1	Casing	AISI 304	1	18	Splash ring	NBR	1	53	Terminal box cover [1]	Polypropylene	1
3	Motor bracket	Aluminium	1	19	Pump side ball bearing	-	1	56	Box gasket	NBR	1
4	Casing cover	AISI 304	1	20	Fan side ball bearing	-	1	73#	Casing ring [3]	NBR/AISI 304	1
6	Shaft with rotor	AISI 303 ^(#1 contact with liquid)	1	21	Adjusting ring	Steel C70	1	75	Washer	AISI 304	2
7	Impeller	AISI 304	1	22	Tie rod	Fe 42 Zinc	4	77#	O-ring	NBR	2
11#	Mechanical seal	Ceramic/Carbon/NBR	1	23	Capacitor [1]	-	1	90	Cover gasket [1]	NBR	1
12	Motor frame with stator	-	1	24	Priming/Drain plug	AISI 303	2	92	Lip seal	NBR	1
13	Motor cover	Aluminium	1	26#	O-ring	NBR	1	93	Lip seal	NBR	1
14	Fan	Polypropylene	1	32	Key	AISI 304	1	110	Protector [4]	-	1
15	Fan cover	Steel C70	1	34	Impeller nut	AISI 304	1	200	Screw	Stainless steel A2 UN17323	8
16	Terminal block	-	1	42	Motor support	Aluminium	1	-	-	-	-
17	Terminal box cover	Aluminium [2]	1	52	Terminal box [1]	Polypropylene	1	-	-	-	-

Optional materials see table below [1] Single phase only [2] Three phase only [3] 70/05,70/07, 90/10 only [4] 1.5 kW single phase only

No.	PART NAME	QTY	MATERIAL	
			High temp. version	Hard face seal version
11	Mechanical seal	1	Ceramic/Carbon/Viton	Silicon Carbide/Silicon Carbide/Viton
26	O-ring	1	Viton	Viton
73	Casing ring [3]	1	Viton/AISI 304	Viton/AISI 304
77	O-ring	2	Viton	Viton

SUBMERSIBLE PUMPS

CONSTRUCTIONS - EXPLODED VIEW

50 Hz
V14

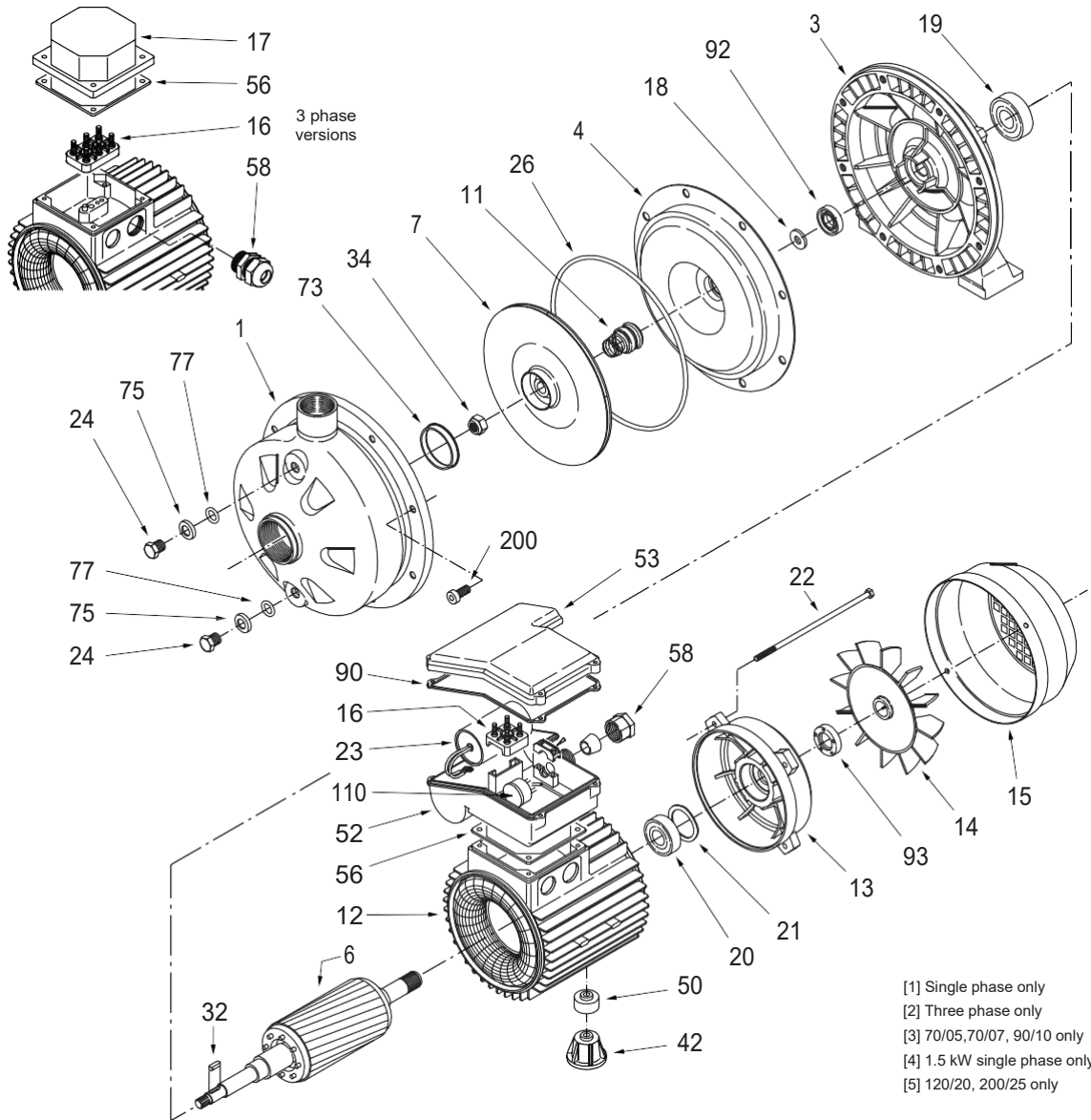

- [1] Single phase only
- [2] Three phase only
- [3] 70/05,70/07, 90/10 only
- [4] 1.5 kW single phase only
- [5] 120/20, 200/25 only

No.	PART NAME	MATERIAL	QTY	No.	PART NAME	MATERIAL	QTY	No.	PART NAME	MATERIAL	QTY
1	Casing	AISI 304	1	18	Splash ring	NBR	1	52	Terminal box [1]	Polypropylene	1
3	Motor bracket	Aluminium	1	19	Pump side ball bearing	-	1	53	Terminal box cover [1]	Polypropylene	1
4	Casing cover	AISI 304	1	20	Fan side ball bearing	-	1	58	Cable Entry	Polypropylene	1
6	Shaft with rotor	AISI 303 ^(in contact with liquid)	1	21	Adjusting ring	Steel C70	1	56	Box gasket	NBR	1
7	Impeller	AISI 304	1	22	Tie rod	Fe 42 Zinc	4	73 [#]	Casing ring [3]	NBR/AISI 304	1
11 [#]	Mechanical seal	Ceramic/Carbon/NBR	1	23	Capacitor [1]	-	1	75	Washer	AISI 304	2
12	Motor frame with stator	-	1	24	Priming/Drain plug	AISI 303	2	77 [#]	O-ring	NBR	2
13	Motor cover	Aluminium	1	26 [#]	O-ring	NBR	1	90	Cover gasket [1]	NBR	1
14	Fan	Polypropylene	1	32	Key	AISI 304	1	92	Lip seal	NBR	1
15	Fan cover	Steel C70	1	34	Impeller nut	AISI 304	1	93	Lip seal	NBR	1
16	Terminal block	-	1	42	Motor support	Aluminium	1	110	Protector [4]	-	1
17	Terminal box cover	Aluminium [2]	1	50	Spacer [5]	Aluminium	1	200	Screw	Stainless steel A2 UN17323	8

Optional materials see table below

No.	PART NAME	QTY	MATERIAL	
			High temp. version	Hard face seal version
11	Mechanical seal	1	Ceramic/Carbon/Viton	Silicon Carbide/Silicon Carbide/Viton
26	O-ring	1	Viton	Viton
73	Casing ring [3]	1	Viton/AISI 304	Viton/AISI 304
77	O-ring	2	Viton	Viton

SUBMERSIBLE PUMP

CONSTRUCTIONS - MECHANICAL SEAL

50 Hz
V14

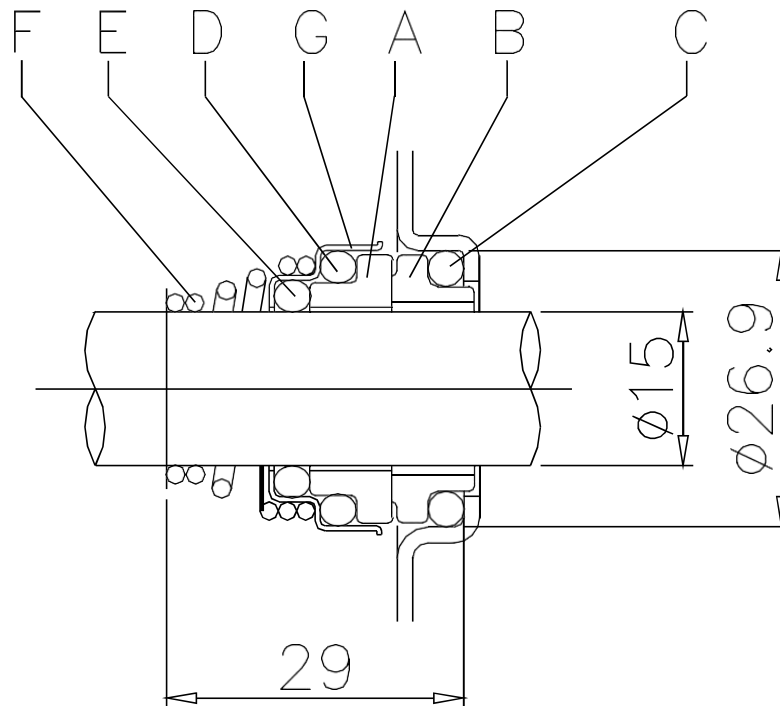

REF	PART NAME	MATERIAL		
		Standard version	High Temp	Optional Hard Face
A	Rotary seal ring	Ceramic	Ceramic	Silicon carbide
B	Stationary seal ring	Carbon graphite	Carbon graphite	Silicon carbide
C	O Ring	NBR	FPM	FPM
D	O Ring	NBR	FPM	FPM
E	O Ring	NBR	FPM	FPM
F	Self driving spring	AISI 316	AISI 316	AISI 316
G	Frame	AISI 304	AISI 304	AISI 316

SUBMERSIBLE PUMP

SINGLE PHASE DIAGRAM AND ELECTRIC CONNECTIONS

50 Hz
V14

FOR MOTORS WITH LOCKED ROTOR CURRENT
UP TO 25 (A)
INTERNAL MOTOR PROTECTOR

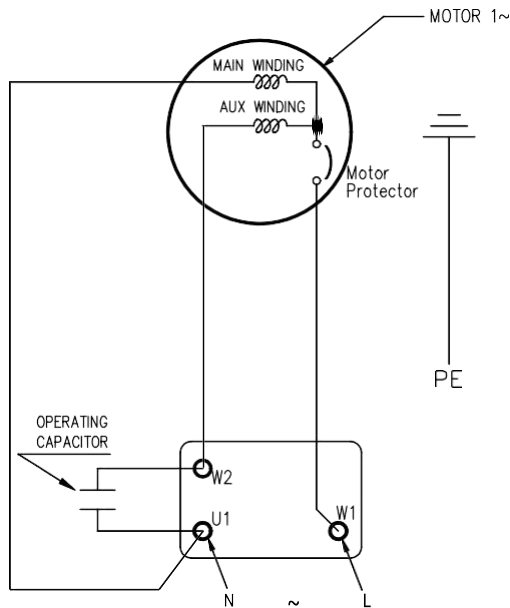

FOR MOTORS WITH LOCKED ROTOR CURRENT
UP TO 25 (A)
EXTERNAL MOTOR PROTECTOR

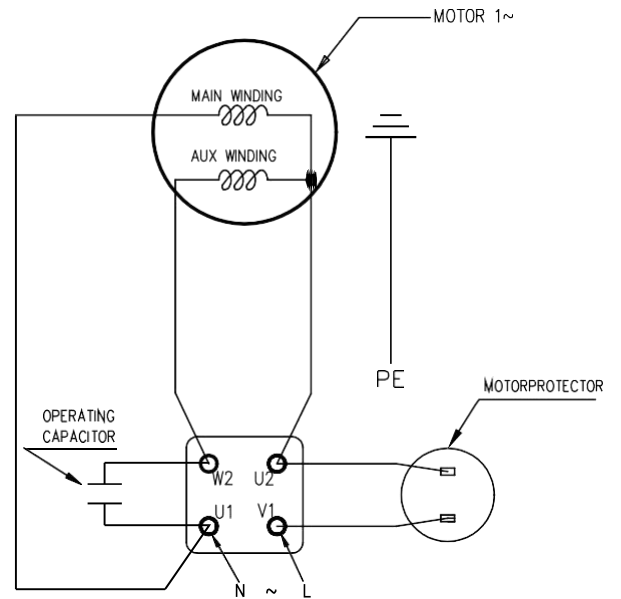

PUMP	MOTORPROTECTOR	
	INTERNAL	EXTERNAL
CDXM 70/05	X	
CDXM 70/07	X	
CDXM 90/10	X	
CDXM 120/07	X	
CDXM 120/12	X	
CDXM 120/20		X
CDXM 200/12	X	
CDXM 200/20		X

SUBMERSIBLE PUMP

THREE PHASE DIAGRAM AND ELECTRIC CONNECTIONS

50 Hz
V14

STAR CONNECTION (400 V)

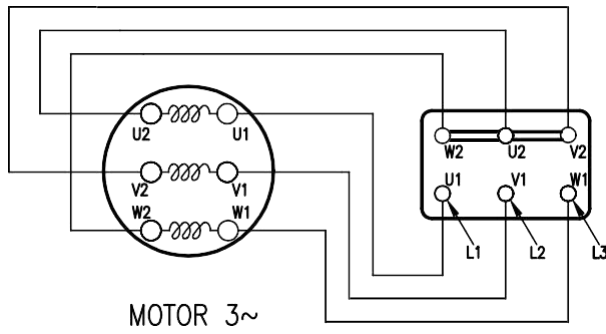

DELTA CONNECTION (230 V)

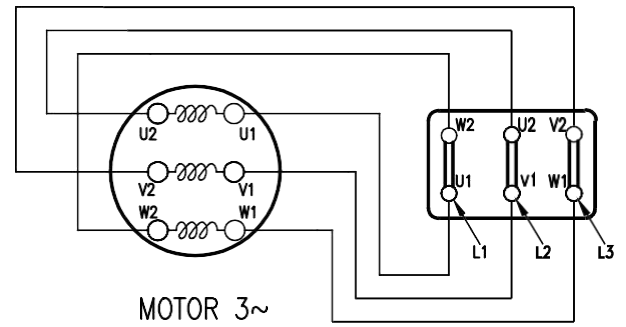

SUBMERSIBLE PUMP

DIMENSIONS

50 Hz
V14

Units: mm unless otherwise specified

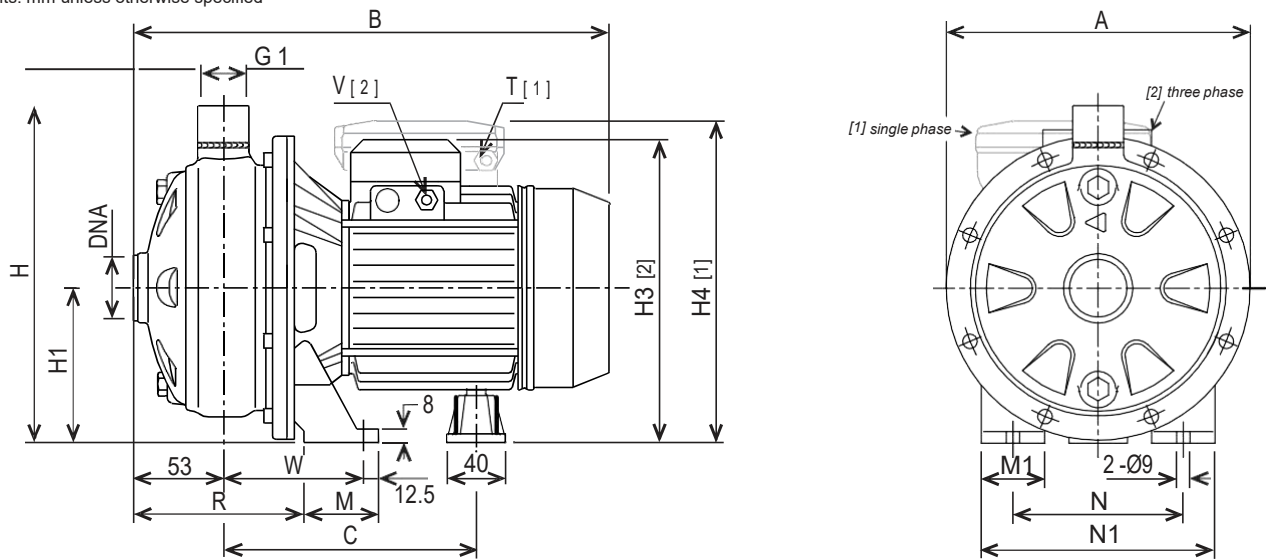

Model	Dimensions																Approx. Weight kg	
	A	[1]	[2]	C	H	H1	H3	H4	M	M1	N	N1	R	T	V	W		DNA (m)
70/05	208	321	320	181	229.5	106	207	216	50	38	120	160	108	PG 11	PG 11	93	G1 ¼	9
70/07	208	321	320	181	229.5	106	207	216	50	38	120	160	108	PG 11	PG 11	93	G1 ¼	10
90/10	208	321	320	181	229.5	106	207	216	50	38	120	160	108	PG 11	PG 11	93	G1 ¼	11
120/07	208	321	320	181	229.5	106	207	216	50	38	120	160	108	PG 11	PG 11	93	G1 ¼	10
120/12	208	321	332	181	229.5	106	207	235	50	38	120	160	108	PG 11	PG 11	93	G1 ¼	12
120/20	231	347	359	199	250	118	237	249	55	40	140	180	105.5	PG 13.5	PG 11	95	G1 ¼	17
200/12	208	321	332	181	229.5	106	207	235	50	38	120	160	108	PG 13.5	PG 11	93	G1 ½	12
200/20	208	347	359	199	229.5	106	225	237	55	40	140	180	105.5	PG 13.5	PG 11	95	G1 ½	16
200/25	232	-	359	199	250	118	237	-	55	40	140	180	105.5	-	PG 11	95	G1 ½	16

SUBMERSIBLE PUMPS

PACKING AND WEIGHT

50 Hz
V14

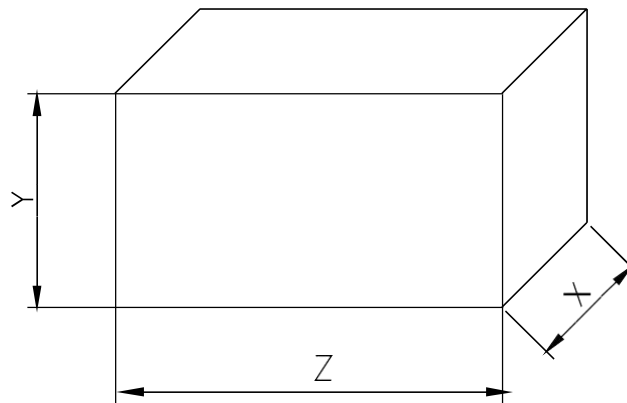

Type		PACKING [mm]			WEIGHT [kg]	
Single Phase	Three Phase	X	Y	Z	Single Phase	Three Phase
CDXM 70/05	CDX 70/05	227	280	335	9.1	9.1
CDXM 70/07	CDX 70/07	227	280	335	10.4	10.4
CDXM 90/10	CDX 90/10	227	280	335	11.9	11.9
CDXM 120/07	CDX 120/07	227	280	335	10.4	10.4
CDXM 120/12	CDX 120/12	227	280	335	12.5	12.5
CDXM 120/20	CDX 120/20	245	315	360	17.2	16.2
CDXM 200/12	CDX 200/12	218	280	332	12.1	12.1
CDXM 200/20	CDX 200/20	250	315	375	15.3	14.2
-	CDX 200/25	245	305	380	-	17

SUBMERSIBLE PUMP

TECHNICAL DATA - MOTOR AND BEARINGS

50 Hz

V14

MOTOR DATA

Pump type		Power		Efficiency		Capacitor		Efficiency (% load)			Input [kW]		Full load current [A]			Locked rotor current [A]		
Single Phase	Three Phase	[kW]	[HP]	Single Phase	Three Phase	Single Phase [μF]	Three Phase [V]	Three phase η %			Single Phase	Three Phase	Single Phase 230 V	Three Phase 230 V	Three Phase 400 V	Single Phase 230 V	Three Phase 230 V	Three Phase 400 V
CDXM 70/05	CDX 70/05	0.37	0.5	-	-	12.5	450	-	-	-	0.75	0.68	3.4	2.4	1.4	10.1	11.0	6.15
CDXM 70/07	CDX 70/07	0.55	0.75	-	-	16	450	-	-	-	1.1	1.0	5.0	3.5	2.0	16.1	17.0	9.7
CDXM 90/10	CDX 90/10	0.75	1.0	-	IE2	20	450	77.2	80.9	81.3	1.2	1.05	5.6	3.3	1.9	22.7	22.0	12.9
CDXM 120/07	CDX 120/07	0.55	0.75	-	IE2	16	450	-	-	-	1.0	1.0	4.6	3.2	1.85	16.1	17.0	9.7
CDXM 120/12	CDX 120/12	0.9	1.2	-	IE2	31.5	450	79.0	81.7	81.6	1.6	1.45	6.9	4.5	2.6	25.0	31.0	17.8
CDXM 120/20	CDX 120/20	1.5	2.0	-	IE2	40	450	80.3	83.4	83.8	2.1	2.09	9.3	7.0	4.0	43.0	34.3	20.0
CDXM 200/12	CDX 200/12	0.9	1.2	-	IE2	31.5	450	79.0	81.7	81.6	1.4	1.35	6.3	4.3	2.5	25.0	31.0	17.8
CDXM 200/20	CDX 200/20	1.5	2.0	-	IE2	40	450	80.3	83.4	83.8	2.3	2.22	10.2	7.4	4.3	43.0	34.3	20.0
-	CDX 200/25	1.8	2.5	-	IE2	-	-	83.0	84.4	83.8	-	2.87	-	8.7	5.0	-	59.0	34.3

NOISE DATA

Pump type		Power		L _{PA} - dB(A) *
Single Phase	Three Phase	[kW]	[HP]	
CDXM 70/05	CDX 70/05	0.37	0.5	61
CDXM 70/07	CDX 70/07	0.55	0.75	62
CDXM 90/10	CDX 90/10	0.75	1.0	
CDXM 120/07	CDX 120/07	0.55	0.75	
CDXM 120/12	CDX 120/12	0.9	1.2	64
CDXM 120/20	CDX 120/20	1.5	2.0	
CDXM 200/12	CDX 200/12	0.9	1.2	62
CDXM 200/20	CDX 200/20	1.5	2.0	64
-	CDX 200/25	1.8	2.5	65

* Mean value of several measures at 1m distance around the pump.

Tolerance ± 2.5 dB.

BEARINGS

Pump type		Ball Bearing	
Single Phase	Three Phase	Pump side	Fan side
CDXM 70/05	CDX 70/05	6203 2RSH	6202 2RSH
CDXM 70/07	CDX 70/07	6203 2RSH	6202 2RSH
CDXM 90/10	CDX 90/10	6203 2RSH	6202 2RSH
CDXM 120/07	CDX 120/07	6203 2RSH	6202 2RSH
CDXM 120/12	CDX 120/12	6203 2RSH	6202 2RSH
CDXM 120/20	CDX 120/20	6204 2RSH	6203 2RSH
CDXM 200/12	CDX 200/12	6203 2RSH	6202 2RSH
CDXM 200/20	CDX 200/20	6204 2RSH	6203 2RSH
-	CDX 200/25	6204 2RSH	6203 2RSH